

**Preliminary DATA SHEET**

**CFORTH-SFP+-10G-LR**

*10Gb SFP+ LR Transceiver*

**CFORTH-SFP+-10G-LR Overview**

CFORTH-SFP+-10G-LR SFP+ optical transceivers are based on 10G Ethernet IEEE 802.3ae standard and SFF 8431 standard, and provide a quick and reliable interface for the 10G Ethernet application. The Digital diagnostics functions are available via 2-wire serial bus specified in the SFF 8472.

**Product Features**

- Up to 10.7 GbD bi-directional data links
- Compliant with IEEE 802.3ae 10GBASE-LR/LW
- Compliant with 10GFC
- Compliant with SFF8431
- Hot-pluggable SFP+ footprint
- 1310nm DFB laser transmitter
- Duplex LC connector
- Built-in digital diagnostic functions
- Up to 10km on SMF
- Single power supply 3.3V
- RoHS Compliance
- Operating temperature range: 0°C to 70°C.

**Applications**

- 10GBASE-LR/LW Ethernet
- 10GFC

**Ordering Information**

---

<i>Part Number</i>	<i>Description</i>
CFORTH-SFP+-10G-LR	10GBASE-LR SFP+ 1310nm LC Connectors 10km on SMF, with DOM function.

---

**General Specifications**

<i>Parameter</i>	<i>Symbol</i>	<i>Min</i>	<i>Typ</i>	<i>Max</i>	<i>Unit</i>	<i>Remarks</i>
Data Rate	$DR$		10.3125		GBd	IEEE 802.3ae
Bit Error Rate	$BER$			$10^{-12}$		
Operating Temperature	$T_{OP}$	0		70	°C	Case temperature
Storage Temperature	$T_{STO}$	- 40		85	°C	Ambient temperature
Supply Current	$I_S$		230	300	mA	For electrical power interface
Input Voltage	$V_{CC}$	3	3.3	3.6	V	
Maximum Voltage	$V_{MAX}$	- 0.5		4	V	For electrical power interface

**Link Distances**

<i>Parameter</i>	<i>Fiber Type</i>	<i>Distance Range (Km)</i>
10.3125 GBd	9/125um SMF	10

**Optical Characteristics – Transmitter** $V_{CC}=3V$  to  $3.6V$ ,  $T_C=0\text{ }^{\circ}\text{C}$  to  $70\text{ }^{\circ}\text{C}$ 

<i>Parameter</i>	<i>Symbol</i>	<i>Min</i>	<i>Typ</i>	<i>Max</i>	<i>Unit</i>	<i>Remarks</i>
Output Optical Power	$P_{TX}$	- 8.2		0.5	dBm	Average
Optical Center Wavelength	$\lambda_C$	1260		1355	nm	
Optical Modulation Amplitude	$OMA$	- 5.2				Per IEEE 802.3ae
Extinction Ratio	$ER$	3.5	5.5		dB	
Spectral Width (- 20 dB)	$\Delta\lambda$			0.6	nm	
Side Mode Suppression Ratio	$SMSR$	30			dB	
Relative Intensity Noise	$RIN$			- 128	dB/Hz	
Transmitter Dispersion Penalty	$TDP$			3.2	dB	
Transmitter Jitter		According to IEEE 802.3ae requirement				
Launch Power of OFF Transmitter	$P_{OUT\_OFF}$			- 30	dBm	Average

**Optical Characteristics – Receiver** $V_{CC}=3V$  to  $3.6V$ ,  $T_C=0\text{ }^{\circ}\text{C}$  to  $70\text{ }^{\circ}\text{C}$ 

<i>Parameter</i>	<i>Symbol</i>	<i>Min</i>	<i>Typ</i>	<i>Max</i>	<i>Unit</i>	<i>Remarks</i>
Optical Center Wavelength	$\lambda_C$	1260		1355	nm	
Optical Input Power	$P_{IN}$	-14.4		0.5	dBm	Average, Informative
Receiver Sensitivity (OMA)@ 10.3GBd	$R_{X\_SEN1}$			- 14.4	dBm	Measured with worst ER: BER< $10^{-12}$ 2 <sup>31</sup> -1 PRBS
Stressed Receiver Sensitivity in OMA @ 10.3Gb/s	$P_{SENS2}$			- 10.3	dBm	IEEE 802.3ae
Receiver Reflectance	$TR_{RX}$			- 12	dB	
LOS Assert	$LOS_A$	- 30			dBm	
LOS De-Assert	$LOS_D$			- 14	dBm	
LOS Hysteresis		0.5			dB	

**Electrical Characteristics – Transmitter** $V_{CC}=3V$  to  $3.6V$ ,  $T_C=0\text{ }^{\circ}\text{C}$  to  $70\text{ }^{\circ}\text{C}$ 

<i>Parameter</i>	<i>Symbol</i>	<i>Min</i>	<i>Typ</i>	<i>Max</i>	<i>Unit</i>	<i>Remarks</i>
Input differential impedance	$R_{IN}$		100		$\Omega$	Non condensing
Single ended data input swing	$V_{IN\_PP}$	250		800	mV	
Transmit disable voltage	$V_D$	2		$V_{CC}$	V	
Transmit enable voltage	$V_{EN}$	$V_{EE}$		$V_{EE}+0.8$	V	

**Electrical Characteristics – Receiver** $V_{CC}=3V$  to  $3.6V$ ,  $T_C=0\text{ }^{\circ}\text{C}$  to  $70\text{ }^{\circ}\text{C}$ 

<i>Parameter</i>	<i>Symbol</i>	<i>Min</i>	<i>Typ</i>	<i>Max</i>	<i>Unit</i>	<i>Remarks</i>
Single ended data output swing	$V_{OUT\_PP}$	150	300	425	mV	
Data output rise time (20%-80%)	$T_R$		30		ps	
Data output fall time (20%-80%)	$T_F$		30		ps	
LOS Fault	$V_{LOS\_Fault}$	2		$V_{CC\_HOST}$	V	
LOS Normal	$V_{LOS\_normal}$	$V_{EE}$		$V_{EE}+0.5$	V	

### Digital Diagnostic Functions

CFORTH-SFP+-10G-LR support the 2-wire serial communication protocol as defined in the SFF 8472. Digital diagnostic information are accessible over the 2-wire interface at the address 0xA2. Digital Diagnostics for CFORTH-SFP+-10G-LR are internally calibrated by default. A micro controller unit inside the transceiver gathers the monitoring information and reports the status of transceiver.

**Transceiver Temperature**, internally measured, represented as a 16 bit signed twos complement value in increments of 1/256 degrees Celsius, Temperature accuracy is better than  $\pm 3$  degrees Celsius over specified operating temperature and voltage.

**Transceiver Supply Power**, internally measured, represented as a 16 bit unsigned integer with the voltage defined as the full 16 bit value (0 – 65535) with LSB equal to 100  $\mu$ Volt, yielding a total range of 0 to +6.55 Volts.

**Transceiver TX bias current**, internally measured, represented as a 16 bit unsigned integer with the current defined as the full 16 bit value (0 – 65535) with LSB equal to 2  $\mu$ A, yielding a total range of 0 to 131mA. Accuracy is better than  $\pm 10\%$  over specified operating temperature and voltage.

**Transceiver TX output power**, internally measured, represented as a 16 bit unsigned integer with the power defined as the full 16 bit value (0 – 65535) with LSB equal to 0.1  $\mu$ W. Data is assumed to be based on measurement of laser monitor photodiode current. Accuracy is better than  $\pm 3$ dB over specified temperature and voltage. Data is not valid when the transmitter is disabled.

**Transceiver RX received optical power**, internally measured, represented as a 16 bit unsigned integer with the power defined as the full 16 bit 35 value (0 – 65535) with LSB equal to 0.1  $\mu$ W. Accuracy is better than  $\pm 3$ dB over specified temperature and voltage.

## Block Diagram of Transceiver

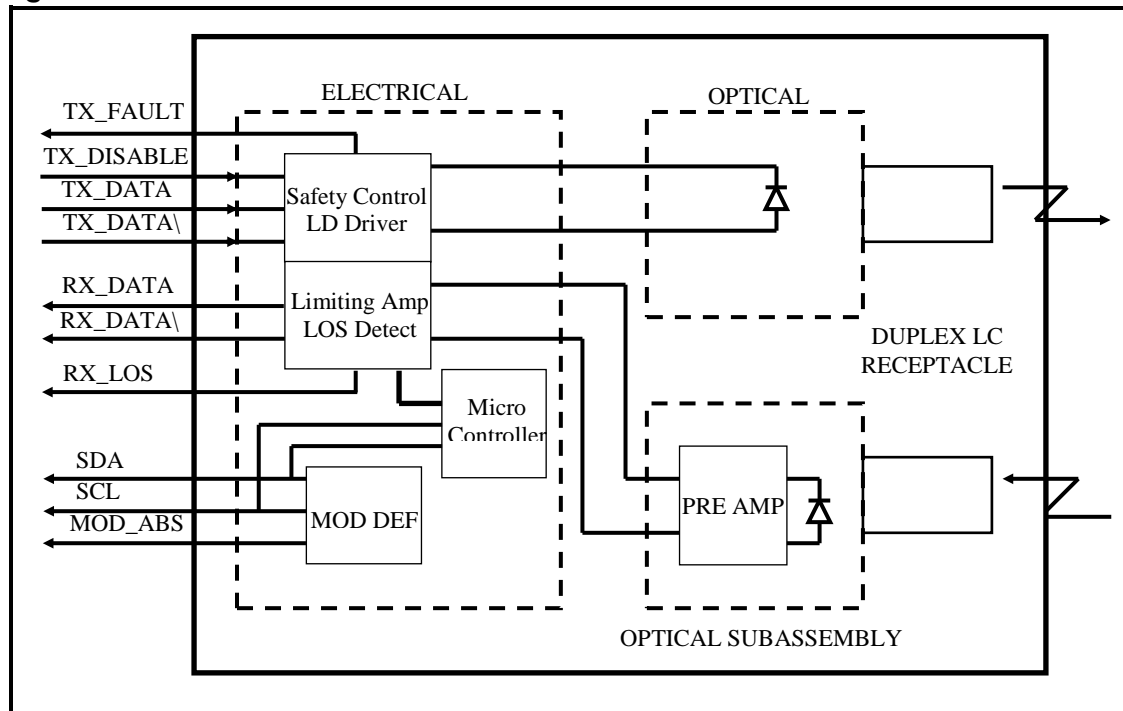

### Transmitter Section

The Laser driver accept differential input data and provide bias and modulation currents for driving a laser. An automatic power-control (APC) feedback loop is incorporated to maintain a constant average optical power. 1310 DFB in an eye safe optical subassembly (OSA) mates to the fiber cable.

### TX\_DISABLE

The TX\_DISABLE signal is high (TTL logic "1") to turn off the laser output. The laser will turn on within 1ms when TX\_DISABLE is low (TTL logic "0").

### TX\_FAULT

When the TX\_FAULT signal is high, output indicates a laser fault of some kind. Low indicates normal operation.

### Receiver Section

The receiver utilizes a PIN detector integrated with a trans-impedance preamplifier in an OSA. This OSA is connected to a Limiting Amplifier which providing post-amplification quantization, and optical signal detection. The limiting Amplifier is AC-coupled to the transimpedance amplifier, with internal 100Ω differential termination.

### Receive Loss (RX\_LOS)

The RX\_LOS is high (logic "1") when there is no incoming light from the companion transceiver. This signal is normally used by the system for the diagnostic purpose. The signal is operated in TTL level.

### Controller Section

The micro controller unit monitors the operation information of LD driver and Limiting Amplifier. And report these status to the customer.

Dimensions

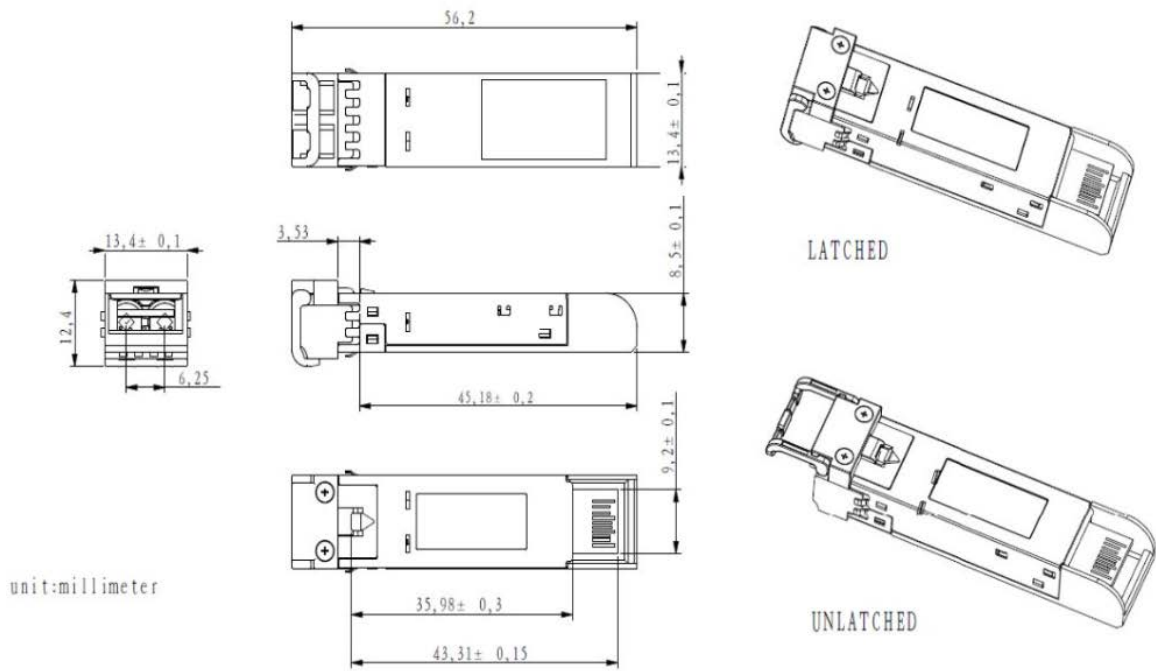

ALL DIMENSIONS ARE ±0.2mm UNLESS OTHERWISE SPECIFIED  
UNIT: mm

PCB Layout Recommendation

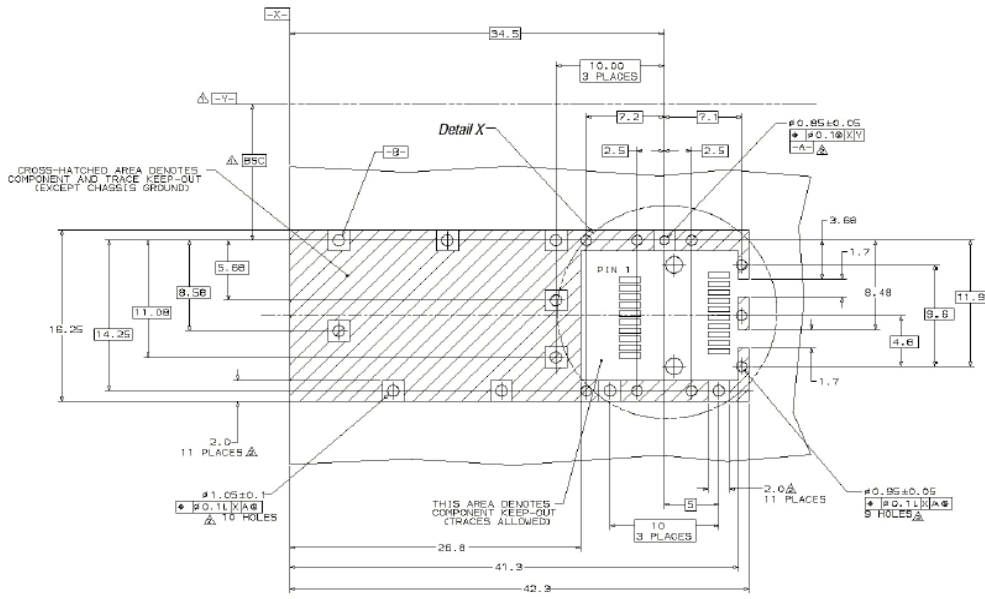

- Datum and Basic Dimension Established by Customer
- Rads and Vias are Chassis Ground, 11 Places
- Through Holes are Unplated

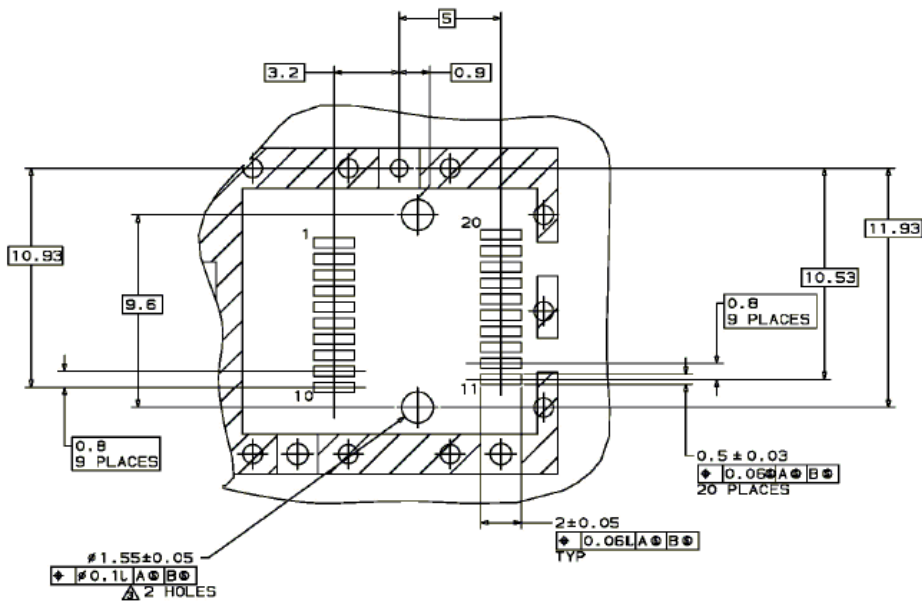

Electrical Pad Layout

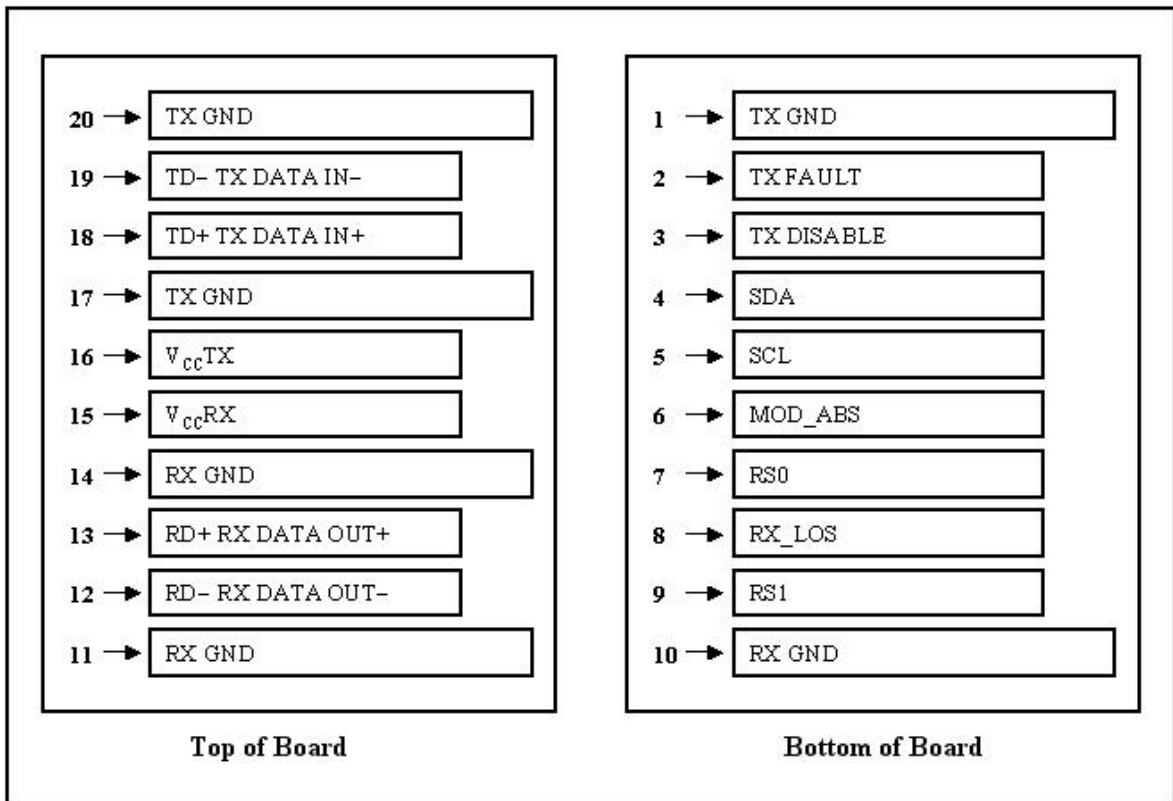
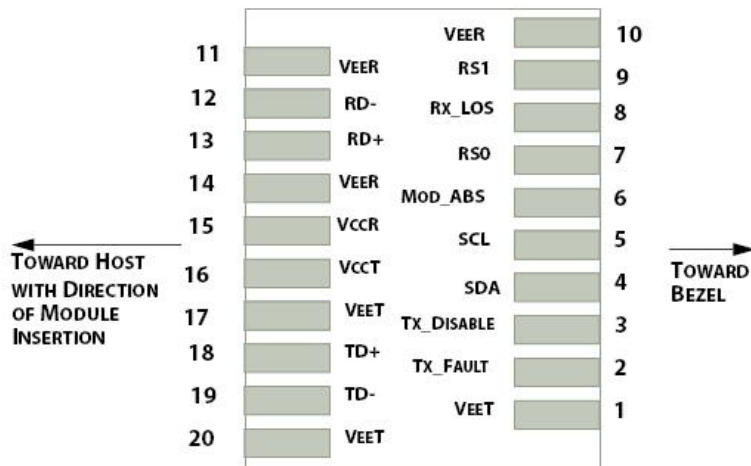



**Pin Assignment**

<i>PIN #</i>	<i>Symbol</i>	<i>Description</i>	<i>Remarks</i>
1	V <sub>EET</sub>	Transmitter ground (common with receiver ground)	Circuit ground is isolated from chassis ground
2	T <sub>FAULT</sub>	Transmitter Fault.	
3	T <sub>DIS</sub>	Transmitter Disable. Laser output disable on high or open	Disabled: T <sub>DIS</sub> >2V or open Enabled: T <sub>DIS</sub> <0.8V
4	SDA	Data line for serial ID	Should Be pulled up with
5	SCL	Clock line for serial ID	4.7k – 10k ohm on host
6	MOD_ABS	Module Absent. Grounded within the module	board to a voltage between 2V and 3.6V
7	RS0	No connection required	
8	LOS	Loss of Signal indication. Logic 0 indicates normal operation	LOS is open collector output
9	RS1	No connection required	
10	V <sub>EER</sub>	Receiver ground (common with transmitter ground)	Circuit ground is isolated from chassis ground
11	V <sub>EER</sub>	Receiver ground (common with transmitter ground)	
12	RD-	Receiver Inverted DATA out. AC coupled	
13	RD+	Receiver Non-inverted DATA out. AC coupled	
14	V <sub>EER</sub>	Receiver ground (common with transmitter ground)	Circuit ground is isolated from chassis ground
15	V <sub>CCR</sub>	Receiver power supply	
16	V <sub>CCT</sub>	Transmitter power supply	
17	V <sub>EET</sub>	Transmitter ground (common with receiver ground)	Circuit ground is isolated from chassis ground
18	TD+	Transmitter Non-Inverted DATA in. AC coupled	
19	TD-	Transmitter Inverted DATA in. AC coupled	
20	V <sub>EET</sub>	Transmitter ground (common with receiver ground)	Circuit ground is isolated from chassis ground

**References**

1. IEEE standard 802.3ae. IEEE Standard Department, 2005.
2. Enhanced 8.5 and 10 Gigabit Small Form Factor Pluggable Module "SFP+" – SFF-8431
3. Digital Diagnostics Monitoring Interface for Optical Transceivers – SFF-8472.